

ULINE H-279

**DELUXE STEEL
STRAPPING CART**

1-800-295-5510

uline.com



Wear safety glasses and gloves. Edges of the steel liner may be sharp. Use care in removing the liner and properly discard the liner.

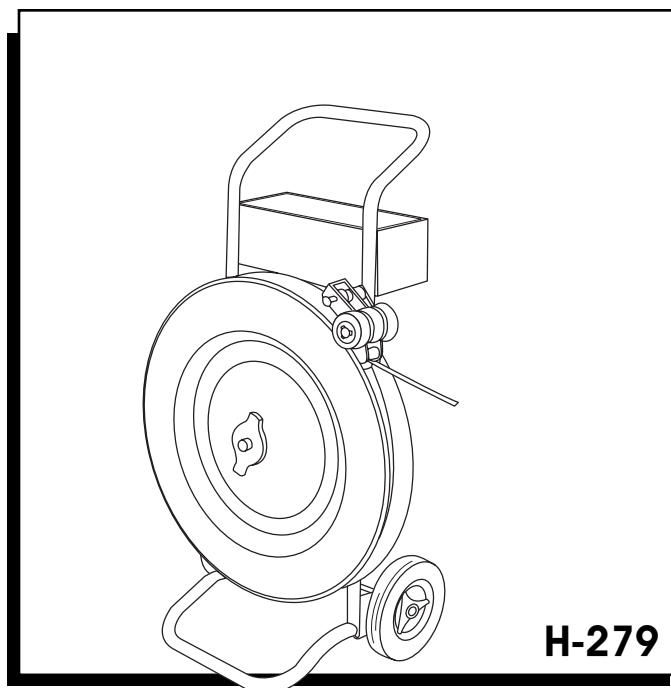

H-279

INSTRUCTIONS

LOAD NEW COIL OF STRAPPING



NOTE: Instructions apply for loading a 16" diameter core of plastic or steel strapping.

1. Lay the dispenser down on its back and loosen the wing nut by turning it counter-clockwise.
2. Remove the wing nut and the front reel disc assembly.
3. Note the pay-off direction of the lead end. When the coil is mounted, the lead end should point toward the brake arm strapguide. As the strap is used, the coil and flanges will rotate in the clockwise direction,
4. Place a new coil of strapping in the dispenser.



CAUTION: Steel strapping is heavy. Use proper lifting techniques to avoid personal injury. Always wear gloves when handling steel strapping.

5. Align and center the larger coil core and lower the new coil over the central hub, allowing it to settle over the smaller circular indentation on the hub reel disc.
6. Cut and remove the tie closest to the lead-end of the strapping.
7. Thread the lead end through the brake arm strapguide.

8. Cut and remove the remaining ties. For steel strapping, replace the front reel disc with the core indentation facing inward so that the indentation fits into the core of the coil. The flat face of the front reel assembly should be facing outward.
9. Place the front reel disc assembly on the coil.
10. Replace and securely tighten the wing nut by turning it in the clockwise direction.



CAUTION: The wing nut must be tight to prevent tangling of strapping.

11. When the wing nut is secure, stand the dispenser upright. Turn the lead-end back on itself over the strapguide assembly to prevent personal injury.

REMOVE THE LEFTOVER STEEL LINER

1. Placing one hand on each side of the locking tab and grasp the liner. Bow the liner inward.
2. Lift upwards to free the liner from the base flange. Hold both ends of the liner firmly and lift the tab end to disengage the lock.
3. Allow the liner to slowly straighten before releasing either end.