

ULINE H-950
SHRINKFAST
HEAT GUN #998

1-800-295-5510
uline.com

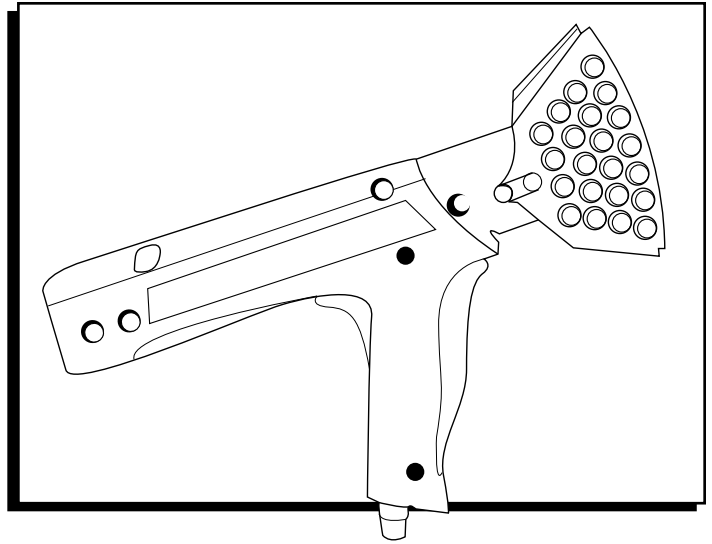

GENERAL SAFETY PROVISIONS

Read this manual thoroughly to familiarize yourself with the parts and safe operation of this tool. Keep for future reference.

- Never point the gun at another person.
- Inspect hose before each use.
- Always shut off valve at tank when leaving gun unattended for any length of time.
- Safety trigger mechanism automatically shuts off if gun is dropped.



WARNING! BURN DANGER

Do not touch wire metal shield after gun has been used.

TECHNICAL SPECIFICATIONS

DISTANCE (ft.)	TEMPERATURE (°F)	VELOCITY (ft./min.)
1/2	1,120	2,100
1	650	1,200
2	390	660

Heat Capacity: 172,500 BTU/Hr

Propane Consumption: 8.0 Lbs./Hr

Operating Pressure (Preset): 22.5 PSIG

Weight: 2 lbs. 20 oz.

Air Consumption: 30 cfm

Emissions: .015 CO/CO₂

GENERAL INFORMATION

SHRINK FILM

Use only with shrink film (not all plastic films are shrink film). Shrink film should be virgin plastic, not reprocessed material. For light loads of 100 lbs. or less, 3 mil thick film should work. For heavy weights or items (example, steel drums at 2,000 lbs./pallet) use 6 mil or thicker shrink film.

- Gusseted film shrinks equally in both directions, tend to pull up and away from pallet. Length should be longer than the height of the pallet.
- Centerfold film shrinks mainly in one direction, and have a reduced tendency to pull up off of pallet.

FIGURING BAG SIZE

Most bags list lay-flat length and width. To determine what size bag you need, use the following example:

Load size: 47 x 30 x 36" (L x W x H)

Calculate the width of bag:

1. Add the width and length
 $30 + 47" = 77"$
2. Add the Fitting Allowance
 $4 + 77" = 81"$ (This is the width bag you'll need.)

Calculate the length of the bag:

1. Use $\frac{1}{2}$ the length of the shorter side
 $\frac{1}{2}$ of 30" = 15"
2. Add number from Step 1 to height
 $15 + 36" = 51"$
3. Add Shrink Allowance (1" for each foot of height),
 $36" = 3'$, so 3" shrink allowance
 $51 + 3" = 54"$ (This is the length bag you'll need.)
4. Bag size is 54 x 81" (L x W).

PROPANE TANK

Use only with vapor withdrawal propane tanks, NEVER attach heat gun to a liquid withdrawal propane tank.



WARNING! Using a withdrawal propane tank clogs the orifice filter and may result in an extremely dangerous long flame.

Tanks are available in 6, 8, 10, 20, 30 and 40 lb. sizes. 6 lb. tanks are adequate for intermittent use. Use larger tanks for continuous use.

Tank Pressure – Depends on tank temperature. At 72°F, pressure is 110 PSI; at 0°F, pressure drops to 22 PSI. In use, tank pressure drops due to evaporation process of converting liquid propane to propane gas. Tank may drop to 0°F with ice appearing on the outside. Propane pressure may drop below 15 PSI.



WARNING! DO NOT run the gun when tank pressure drops below 15 PSI.

- For continuous operation, use multiple tanks, switching the gun from one to another.
- Using an ordinary desk fan to blow air on the tank will prevent it from icing up.

VENTILATION

In use, this heat gun produces carbon dioxide, carbon monoxide and water vapor.



WARNING! Prolonged exposure to carbon monoxide (CO) is lethal. Provide adequate ventilation when gun is used indoors.

To maintain a safe CO concentration (50 parts per million as set by OSHA Standard 1910.93), ventilation requirements are 2,000 cu. ft./min. of fresh air while gun is operated at maximum operating pressure of 30 PSI.

Ventilation capacity should be sized proportionally for different production rates.



EXAMPLE: Based on a 1½ minute heating cycle per pallet, fresh air requirements are 3,000 cu. ft./pallet. If the production rate is 10 pallets/hour, a ventilation system needs to provide 500 cu. ft./minute.

In areas where ventilation is provided by open doors or windows, safe CO levels will maintain as long as room temperature does not exceed 150°F.

OPERATING INSTRUCTIONS

PARTS AND FUNCTIONS

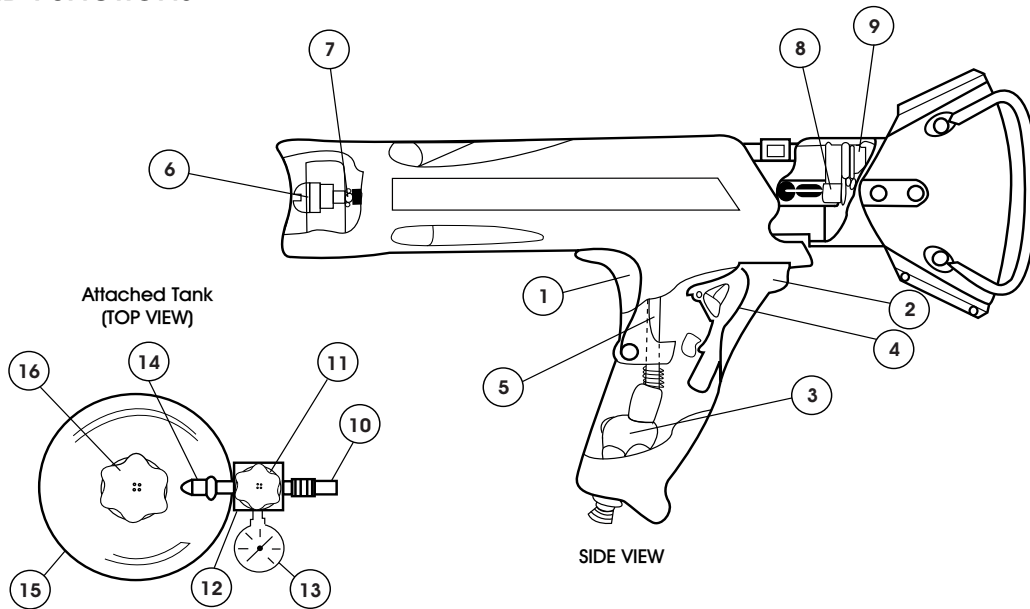

NO.	PART	FUNCTION
1	Safety Trigger	Prevents accidental gas release.
2	Gas Handle	Actuates gas valve and igniter.
3	Gas Valve	Opens fuel flow.
4	Igniter	Fire piezoelectric spark igniter.
5	Fuel Line	Carries fuel to orifice.
6	Filter	Prevents clogging.
7	Orifice	Meters fuel.
8	Spark Plug	Ignites fuel/air mixture.
9	Flame Holder	Prevents flashback and flame out.
10	Hose	Connects regulator and gun.
11	Regulator	Regulates pressure to gun.
12	Adjustment Screw	Sets pressure.
13	Pressure Gauge	Indicates line pressure.
14	Prest-o-Lite Fitting	Connects and contains excess fuel check valve.
15	Tank	Sold seperately, see Tank info
16	Tank Valve	Opens/closes fuel supply.

CONNECTIONS

1. Connect gun, hose and regulator to the tank. Use a wrench to tighten fittings (left hand threaded). (Figure 1)
2. Check for leaks.
 - Open tank valve without pushing trigger to pressurize the hose. Pressure gauge should read 15 to 30 PSI when gun is not in use.
 - Close tank valve and check pressure gauge, rapid pressure loss indicates a leak. Check all connections.

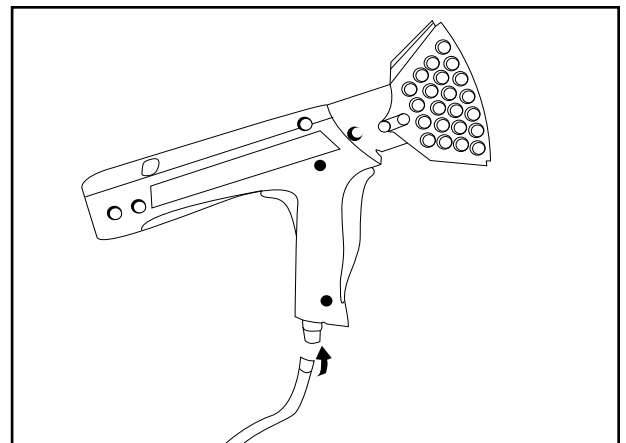
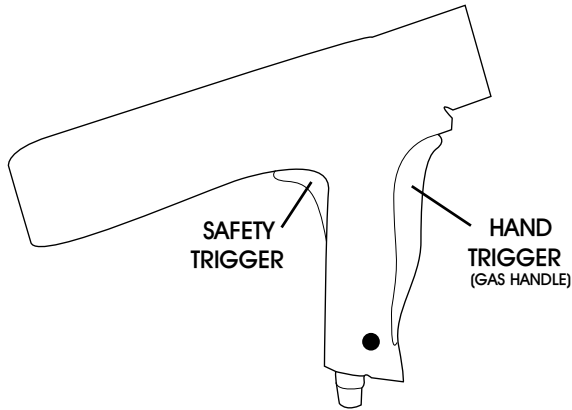

Figure 1

OPERATING INSTRUCTIONS (CONTINUED)

START UP

Open the tank valve, wait 5 seconds to fully pressurize hose. You will hear the flow check valve open with an audible click.



1. Press the safety trigger. This prevents the gas handle from opening accidentally.
2. Slowly squeeze the gas handle until the igniter fires with an audible click.



CAUTION! GUN WILL IGNITE.



IMPORTANT:

- Squeezing the gas handle too quickly will cause the igniter to fire the spark plug before the gas mixture is ready.
- If gun fails to fire fully, release BOTH the safety trigger and gas handle to reset the igniter. Then repeat the starting procedure.
- For thinner films set the regulator for lower pressure and adjust up for thicker films. Factory preset is 22 PSI.

USING THE HEAT GUN

Use gun only in well-ventilated areas.



WARNING! Do not operate gun in areas with flammable gases or where smoking is prohibited.

IMPORTANT HEAT SHRINK TIPS:

- Heat only softens film. Shrinking occurs as film cools. Do not concentrate heat and wait for film to shrink before moving the gun.

- Keep the gun moving. With a little practice, you can hold the gun closer to the film and shrink a pallet in less than 2 minutes.
- Make sure the four corners of the bag are wrapped under pallet.

PALLETIZING

1. Elevate pallet load approx. 6" from floor. Leave area under the four corners clear.
 2. Carefully fit pallet bag over load. Do not puncture or tear the bag. Bag should fit snugly over load and overlap the base of the pallet almost to the floor.
 3. **Shrink Bottom:** Ignite gun and hold about 12" from film.
 - a. Move around pallet applying heat to the bottom edge of the bag and blow it under the pallet.
 - b. Shrink film to grip bottom of pallet firmly, locking bag to pallet and unitizing load.
 4. **Shrink Sides:** Do one side at a time.
 - a. Holding gun 12" from film, shrink side by sweeping gun smoothly across the bottom edge.
 - b. Move up one foot and sweep back, continue to move up and sweep across the side until you reach the top.
-  **IMPORTANT! Keep gun moving at all times.**
- c. Repeat for the remaining sides.
5. **Shrink Top.** Since top is already pulled taut by the four sides being shrunk, this requires less heat than shrinking the sides.

PATCHING

Patch holes easily: Lay a square of film over the hole and apply heat to the edges to weld patch to bag. Also useful for reinforcing edges or corners.

SHRINK WRAPPING LARGE OR ODD-SHAPED LOADS

Wrap objects too big to fit under a bag by joining several sheets of shrink film together.

1. Adjoining sheets should overlap 18".
2. Secure sheets using the weight of the load at the base or with battens tacked to the skids.

CLEANING AND MAINTENANCE

 **NOTE:** Grease all o-rings for easier assembly. Hose adapter fitting is glued permanently into the valve body.

Figure 2

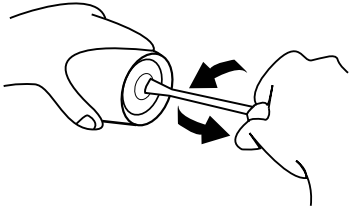

Figure 3

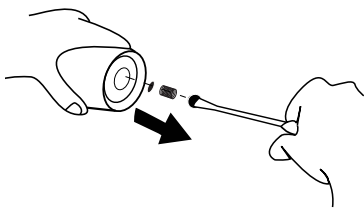

Figure 4

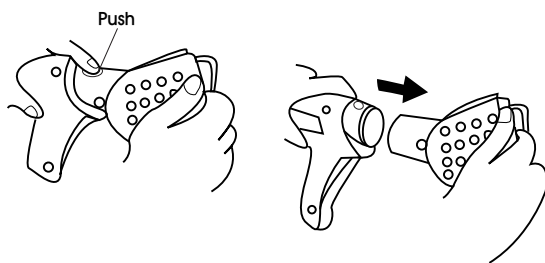

Figure 5

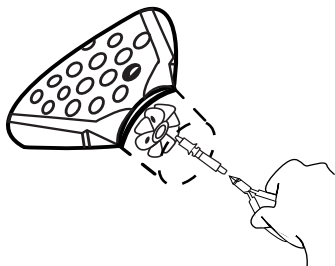
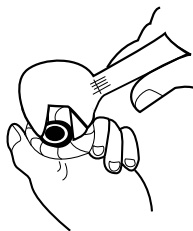

Figure 6



FILTER CLEANING

1. Unscrew the filter holder using a screwdriver or coin. Pull out filter holder. (Figure 2)
2. Remove filter screen/spring assembly. Clean with compressed air or replace. (Figure 3)

REPLACE SPARK PLUG

1. Depress button and remove combustor assembly. (Figure 4)
2. Remove spark plug and flame holder with pliers. (Figure 5)
3. Unscrew spark plug. Set new spark plug gap to 3-5mm. (Figure 6)

CLEANING AND MAINTENANCE (CONTINUED)

Figure 7

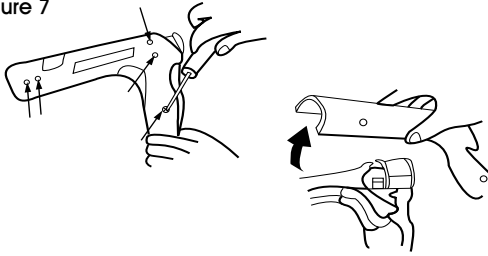

Figure 8

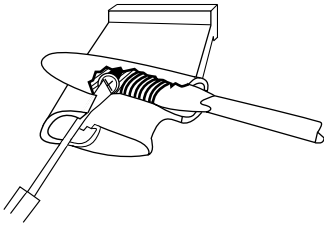

Figure 9

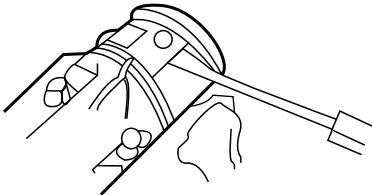

Figure 10

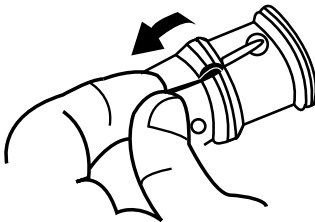

Figure 11

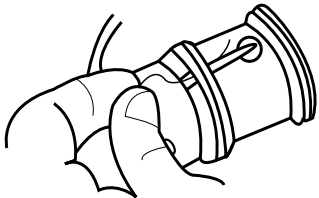
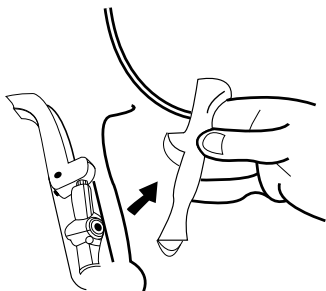

Figure 12



REPLACE IGNITER

1. Remove 5 mounting screws and remove right side of housing. (Figure 7)
2. Remove retaining screw holding the cable and the contact spring. (Figure 8)
3. Use a screwdriver to snap off the clamp. (Figure 9)
4. Pull cable out. (Figure 10)
5. Untie and remove ground strap. (Figure 11)
6. Lift out trigger assembly. (Figure 12)

Figure 13

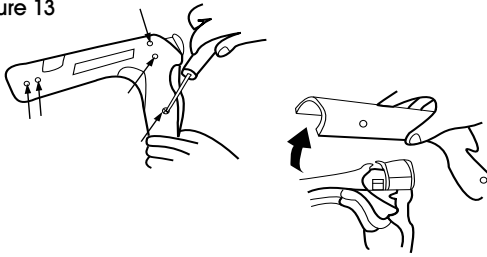

CLEAN OR REPLACE ORIFICE



IMPORTANT! The orifice consists of 6 slender, thin-walled tubes that are easily bent or damaged. Once bent or damaged, gun performance is seriously impaired. Perform the following procedure with **EXTREME CARE**.

1. Remove 5 mounting screws and remove right side of housing. (Figure 13)

Figure 14

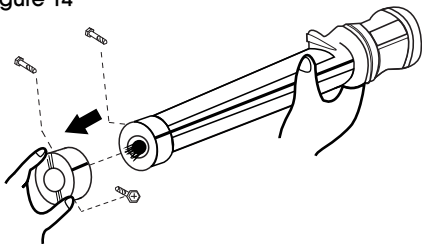

2. Remove the 3 screws holding the pump. (Figure 14)

3. Remove pump by sliding it away from the orifice, then lift it out. (Figure 14)



CAUTION! Lifting the pump before sliding it away will damage the orifice tubes.

Figure 15

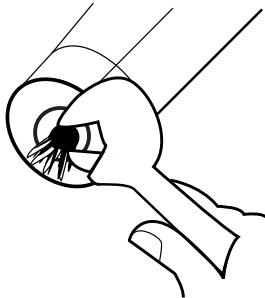

4. Unscrew the orifice. (Figure 15)

Figure 16

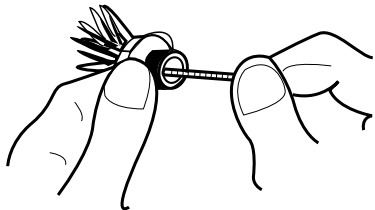

5. Use a .6mm drill bit to clean out each orifice. (Figure 16)

Figure 17

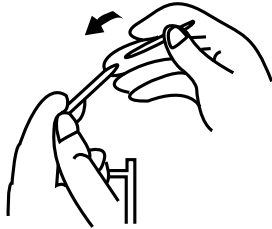

SAFETY CAGE MOUNTING

1. Push both curved tubular joints onto one half of the safety cage. (Figure 17)

Figure 18

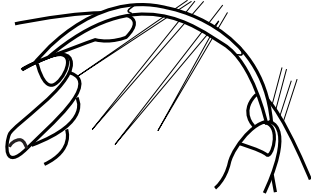

2. Insert the other half of the safety cage into the tubular joints and twist together until mounting struts on both halves are parallel. (Figure 18)

Figure 19

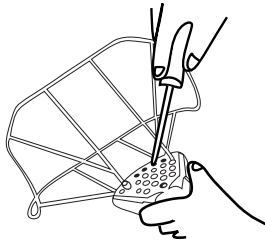

3. Attach cage assembly to the combustor using 4 mounting screws. (Figure 19)

TROUBLESHOOTING

 **NOTE: CHECK TANK FIRST** – Majority of problems are caused by using a liquid withdrawal tank instead of a vapor withdrawal tank.

OPERATING ISSUE	CAUSES	RECOMMENDATIONS
Gun will not fire	Handle not fully depressed. Handle depressed too quickly. Pressure too low. Handle not released fully. Defective igniter or connections. Gas not turned on.	Depress handle all the way until the igniter fires. Listen for a click. Slowly squeeze handle to ensure mixture enters combustor before firing. Check Regulator. Release handle and safety triggers to reset igniter. Check for spark. Return for service. Check On/Off valve.
Combustor turns red *(insufficient fuel flow)	Wrong fuel. Tank used up and tank pressure is below 15 PSIG. Excess flow check valve not open. Clogged orifice and/or filter. Clogged hose. Clogged fuel line.	Check fuel type. Switch to new tank. Open tank valve and wait 10 seconds until hose is pressurized before using gun. Remove and clean with compressed air. Blow or replace. Blow out or replace.
Large flame- fuel flow	Leak in orifice assembly. Wrong pressure.	Tighten orifice in holder and check. Reset to 15-30 PSIG

* Leading edge of combustor turns red under normal conditions. More than 1" of combustor turning red indicates trouble.