

ULINE H-990 ECONOMY PLASTIC PALLET

1-800-295-5510
 uline.com

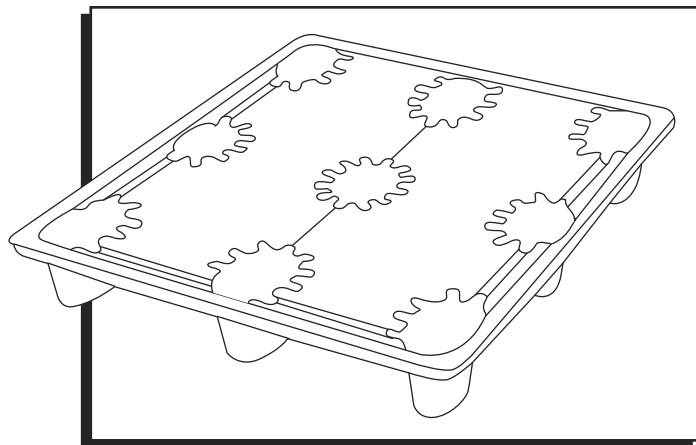

PRODUCT DIAGRAMS

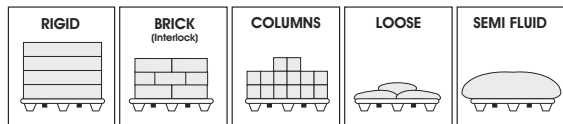
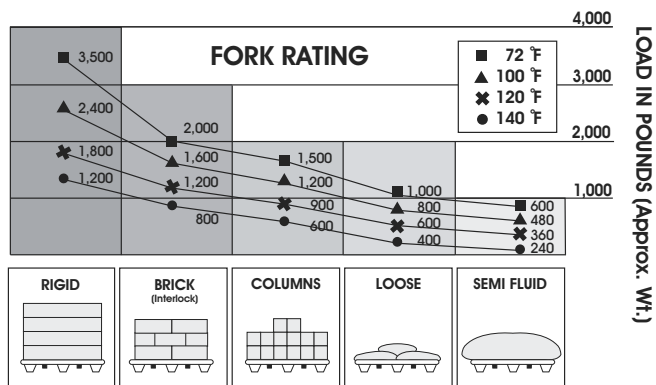

STACKING METHOD

Fork rating differs with stacking method and facility's temperature. Please, note this change as it relates to your application.

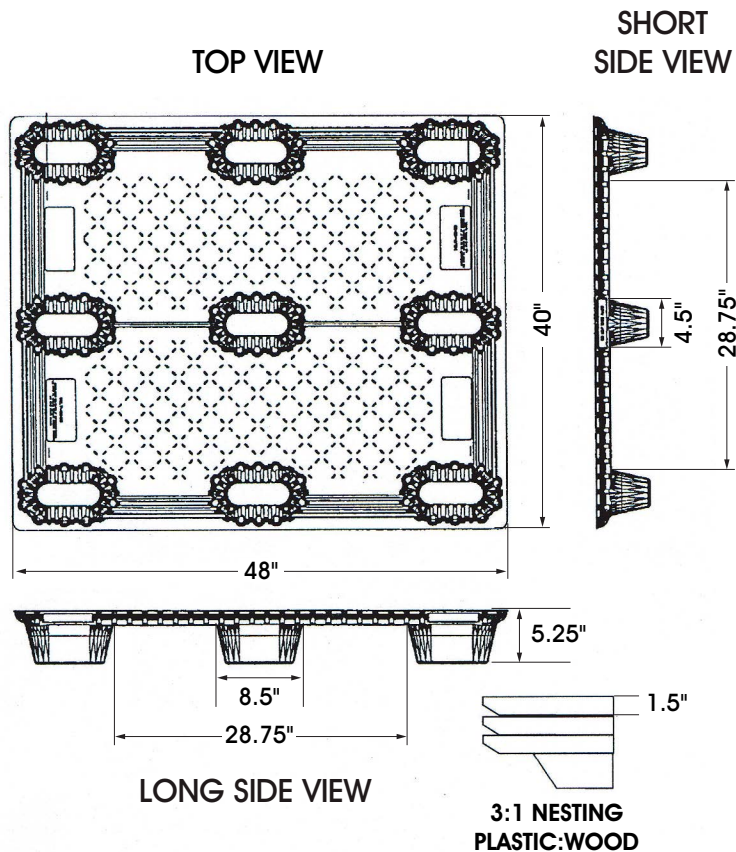

SPECIFICATIONS

MODEL #	DIMENSIONS		HEIGHT			NESTED TRAILER		WEIGHT CAPACITY		WEIGHT
	L	W	FORK	OVERALL	NESTING	48'	53'	FLOOR	FORK	
H-990	48"	40"	3.75"	5.25"	1.5"	1,680	1,800	3,500 lbs.	1,200 lbs.	14 lbs.

ULINE H-990

TARIMA DE PLÁSTICO ECONÓMICA

800-295-5510

uline.mx

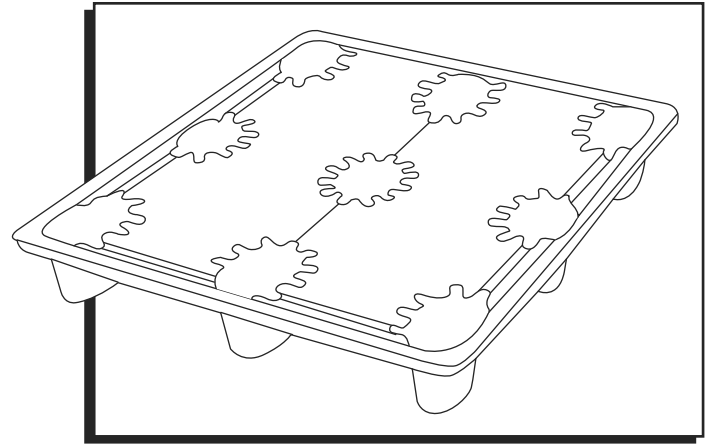

DIMENSIONES DEL PRODUCTO

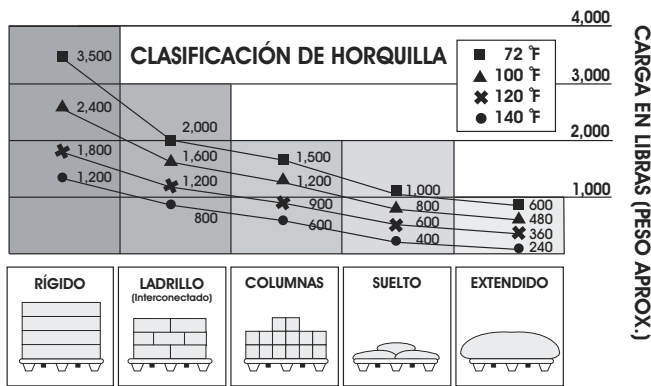

La clasificación de horquilla difiere con el método de estibación y la temperatura de las instalaciones. Favor de notar este cambio conforme se relacione con su aplicación.

CARGA EN LIBRAS (PESO APROX.)

VISTA SUPERIOR

VISTA DEL LADO CORTO

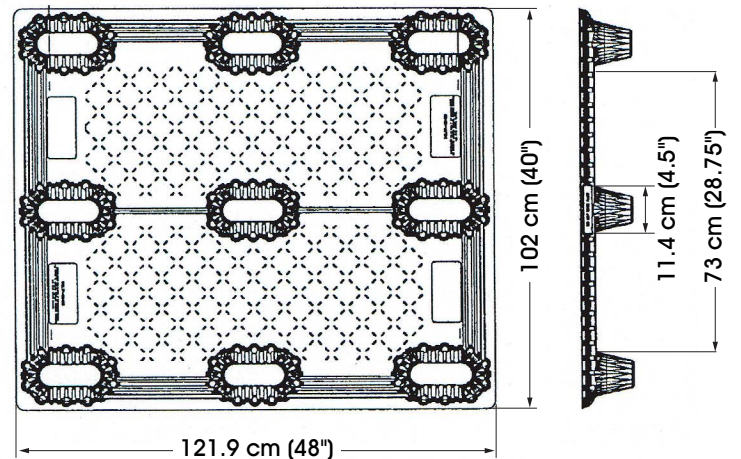

VISTA DEL LADO LARGO

3:1 EMBONABLE PLASTICO:MADERA

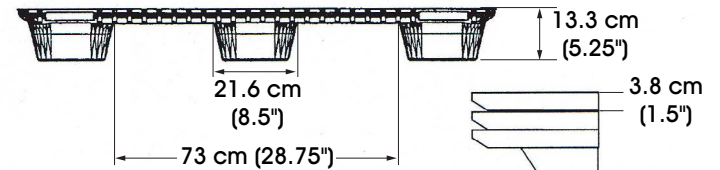

ESPECIFICACIONES

MODELO NO.	DIMENSIONES		ALTURA			EMBOBADAS EN TRÁILER		CAPACIDAD DE PESO		PESO
	LARGO	ANCHO	HORQUILLA	TOTAL	EMBOBADAS	14.6 m (48')	16.15 m (53')	PISO	HORQUILLA	
H-990	121.9 cm (48")	102 cm (40")	9.5 cm (3.75")	13.3 cm (5.25")	3.8 cm (1.5")	1,680	1,800	1,587 kg (3,500 lbs.)	544 kg (1,200 lbs.)	6.4 kg (14 lbs.)

ULINE H-990

PALETTE EN PLASTIQUE ÉCONOMIQUE

1-800-295-5510
uline.ca

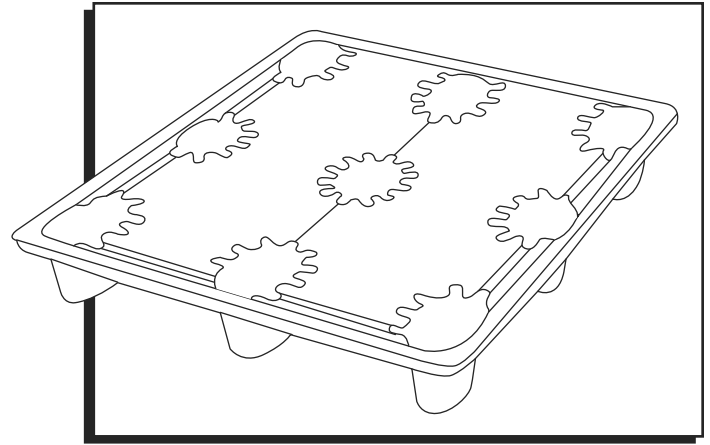

DIMENSIONS DU PRODUIT

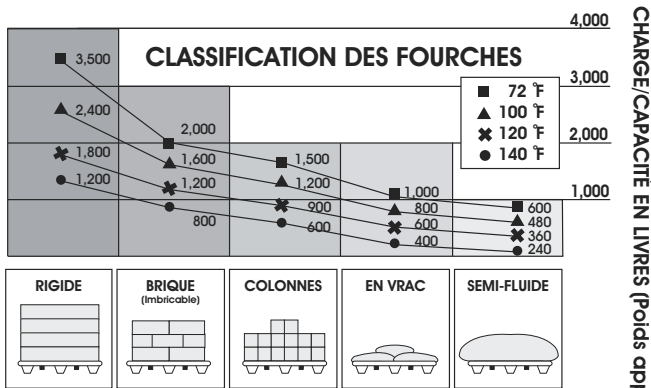

La classification des fourches varie selon la méthode d'empilage et la température de l'établissement. Veuillez prendre note de ce changement relatif à votre utilisation.

CHARGE/CAPACITÉ EN LIVRES (Poids approx.)

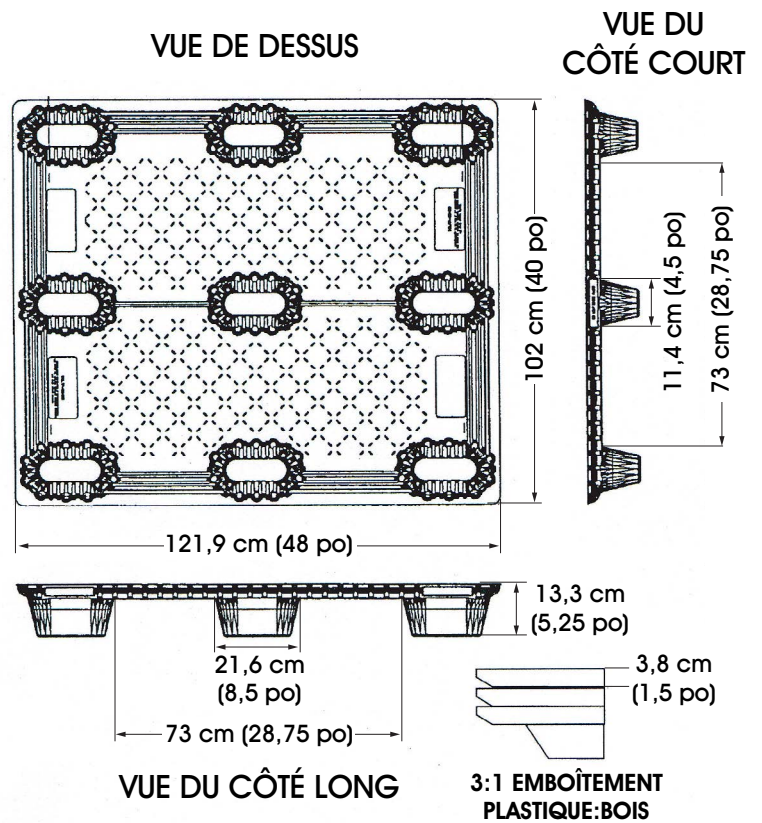

SPÉCIFICATIONS

N° DE MODÈLE	DIMENSIONS		HAUTEUR			REMORQUE EMBOÎTÉE		CAPACITÉ PONDÉRALE		POIDS
	LONG.	LARG.	FOURCHE	TOTALE	EMBOÎTEMENT	14,6 m (48 pi)	16,15 m (53 pi)	PLANCHER	FOURCHE	
H-990	121,9 cm (48 po)	102 cm (40 po)	9,5 cm (3,75 po)	13,3 cm (5,25 po)	3,8 cm (1,5 po)	1 680	1 800	1 587 kg (3 500 lb)	544 kg (1 200 lb)	6,4 kg (14 lb)